

Device	Effect of substances		
	Moisture	Oil	Particles
Solenoid valve	- Malfunction by grease washed out - Stuck valve due to rust - Swollen rubber valve - Reduced service life	- Swollen rubber valve - Reduced service life	- Stuck valve
Air cylinder rotary actuator	- Malfunction by running grease - Stuck valve due to rust - Seized component - Reduced service life	- Reduced service life	- Poor piston rod sealing performance - Reduced service life - Stuck piston rod
Regulator pneumatic relay	- Performance reduction or failure - Reduced service life due to rust	- Performance reduction or failure	- Stuck valve
Pneumatic instrumentation equipment	- Reduced service life due to rust - Malfunction	- Malfunction	
Piping	- Rust formed inside a pipe	- Contamination	
Air duster	- Contamination		
Air motor(Air driver/Air turbine)	- Decreased revolutions - Reduced service life due to rust	- Decreased revolutions or failure	- Failure by seized component
Air blow	- Water droplets generated	- Contamination	
Air micrometer	- Instrumentation error or failure		

Understanding ISO quality air

There are no rules to define what air grade is suitable for each application, but ISO 8573-1 sets a scale depending on the concentration of each substance in the air. It uses three numbers in its classification, in order to set limits on particulate matter, moisture and oil contamination. Class 1, 1, 1 represents the cleanest, purest air under the standard, while -, -, - would represent air too contaminated to make the scale.

ISO 8573-1 air quality classification chart

Class	Solid particles, particle size, d(mm)			Mass concentration Cp [mg/m³]	Humidity and liquid water		Oil Concentration of total oil [mg/m³]	
	Maximum number of particles per cubic meter as a function of particle size d [µm]				Pressure dew point [°C]	Concentration of liquid water Cw [g/m³]		
	0.10 <d ≤0.5	0.5 <d ≤1.0	1.0 <d ≤5.0					
0	As specified by the equipment user or supplier and more stringent than class 1							
1	≤20000	≤400	≤10	—	≤-70	—	≤0.01	
2	≤400000	≤6000	≤100	—	≤-40	—	≤0.1	
3	—	≤90000	≤1000	—	≤-20	—	≤1	
4	—	—	≤10000	—	≤3	—	≤5	
5	—	—	≤100000	—	≤7	—	—	
6	—	—	—	0 <Cp ≤5	≤10	—	—	
7	—	—	—	5 <Cp ≤10	—	Cw ≤0.5	—	
8	—	—	—	—	—	0.5 <Cw ≤5	—	
9	—	—	—	—	—	5 <Cw ≤10	—	
x	—	—	—	Cp >10	—	Cw >10	>5	

SMC Corporation
 Akihabara UDX 15F, 4-14-1
 Sotokanda, Chiyoda-ku, Tokyo 101-0021, JAPAN
 Phone: 03-5207-8249
 Fax: 03-5298-5362

Austria +43 (0)22622800 www.smc.at office@smc.at
Belgium +32 (0)33551464 www.smc.be info@smc.be
Bulgaria +359 (0)2807670 www.smc.bg office@smc.bg
Croatia +385 (0)13707288 www.smc.hr office@smc.hr
Czech Republic +420 541424611 www.smc.cz smc@smcdk.com
Denmark +45 70252900 www.smc.dk info@smc.dk
Estonia +372 651 0370 www.smcee.ee info@smcee.ee
Finland +358 207513513 www.smc.fi smc.fi@smc.fi
France +33 (0)164761000 www.smc-france.fr supportclient@smc-france.fr
Germany +49 (0)61034020 www.smc.de info@smc.de
Greece +30 210 2717265 www.smchellas.gr sales@smchellas.gr
Hungary +36 23513000 www.smc.hu office@smc.hu
Ireland +353 (0)14039000 www.smcautomation.ie sales@smcautomation.ie
Italy +39 03990691 www.smcitalia.it mailbox@smcitalia.it
Latvia +371 67817700 www.smc.lv info@smc.lv

Lithuania +370 5 2306118 www.smc.lt info@smc.lt
Netherlands +31 (0)205318888 www.smc.nl info@smc.nl
Norway +47 67129020 www.smc-norge.no post@smc-norge.no
Poland +48 222119600 www.smc.pl office@smc.pl
Portugal +351 214724500 www.smc.eu apoiclientepl@smc-smcoes.es
Romania +40 213205111 www.smcromania.ro smcromania@smcromania.ro
Russia +7 (812)3036600 www.smc.ru sales@smcru.com
Slovakia +421 (0)413213212 www.smc.sk office@smc.sk
Slovenia +386 (0)73885412 www.smc.si office@smc.si
Spain +34 945184100 www.smc.es post@smc-smcoes.es
Sweden +46 (0)86031240 www.smc.nu smc@smc.nu
Switzerland +41 (0)523963131 www.smc.ch helpcenter.ch@smc.com
Turkey +90 212 489 0 440 www.smc-turkey.com.tr sats@smcturkey.com.tr
UK +44 (0)845 121 5122 www.smc.uk sales@smc.uk

South Africa +27 10 900 1233 www.smcza.co.za zasales@smcza.co.za



Air treatment guide
 Choose your path to the right quality

Atmospheric air contains pollution that remains in the system unless it's removed. Furthermore, not all contamination sources are external, others are added during the compression and supply of the air.

The following table shows how different substances can be removed with the right product for each purpose.

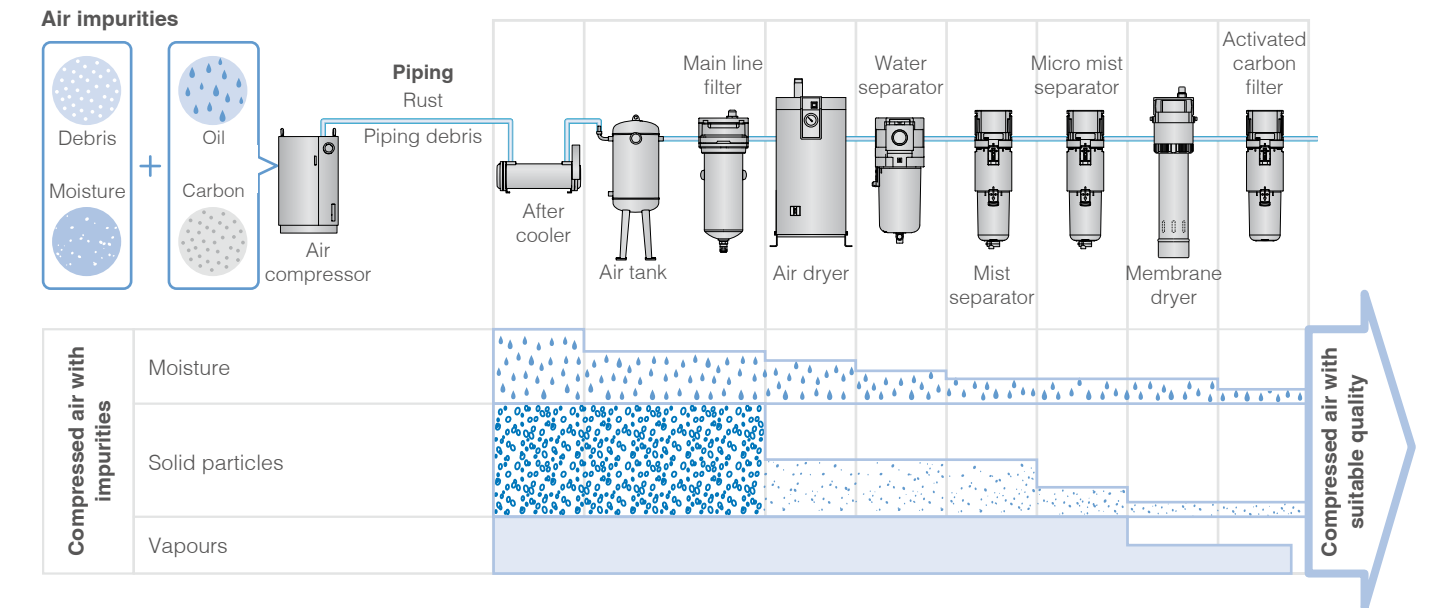

Most common problems in pneumatic systems

If not correctly removed, this foreign matter can result in many different problems, depending on the component and the type of substance.

<p>Moisture and oil Wash out of grease</p>	<p>Swelling of rubber seals</p>	<p>Solidification of powder</p>	<p>Water droplets Contamination of air blow</p>
<p>Rust Piping: stuck auto drains</p>	<p>Devices: corroded pistons and spools</p>	<p>Debris Seal damage</p>	<p>Weather and seasonal problems Over processing due to increased humidity</p>

Model selection guide

This table is a guide to choose the path to the right air quality for different industrial applications. Start by specifying the particle, water and oil parameters that you wish to achieve in your system or by selecting your application and seeing which components can help you fulfil your purpose. For further product information, please visit www.smc.eu.

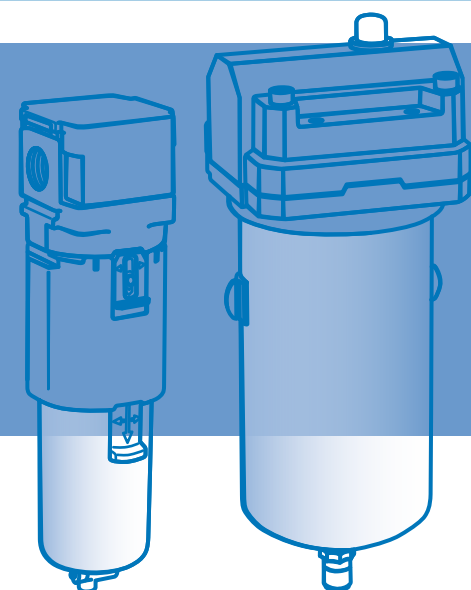

Note 1) When the oil mist concentration (compressor discharge concentration) on the inlet side is approx. 10 mg/m³ (ANR) or less.
 Note 2) Refers to the compressed air quality based on ISO 8573-1:2010 with an inlet air quality [7:4:4].
 Note 3) This describes the grade of compressed air quality based on ISO 8573-1: 2010 (JIS B8392-1: 2012), which is the maximum quality grade for the system. It varies, however, depending on the inlet air conditions.
 Note 4) Inlet air should be adjusted so the products deliver the right quality.

System	Application example	Recommended ISO Air quality class for the application ^{2,4)}	Maximum number of particles per m ³ as a function of particle size d	Humidity and liquid water		Oil	
				Dew point [°C]	Water concentration [g/m ³]	Oil concentration [mg/m ³]	Odour removed
A	Water droplets removed air	5:7:-	1.0 µm < d ≤ 5.0 µm: ≤100000	—	0.5		
	- Air blowing (Simple removal of particles) - General pneumatic tools - Pilot air	4:7:-					
B	Dry air	4:6:-	1.0 µm < d ≤ 5.0 µm: ≤10000	≤10		>5	
		4:5:-		≤7			
C	Dry air	2:6:3	1.0 µm < d ≤ 5.0 µm: ≤100 0.5 µm < d ≤ 1.0 µm: ≤6000 0.1 µm < d ≤ 0.5 µm: ≤400000	≤10		≤1	No
		2:5:3		≤7			
D	Dry & Clean air	1:6:2		≤10		≤0.1	
		1:5:2		≤7			
E	Dry & Clean air	1:6:1		≤10	—		
		1:5:1		≤7			
F	Deodorised air	1:4:1	1.0 µm < d ≤ 5.0 µm: ≤10 0.5 µm < d ≤ 1.0 µm: ≤400 0.1 µm < d ≤ 0.5 µm: ≤20000	≤7			
		1:3:1		≤3			
G	Low dew point clean air	1:3:1		≤-20		≤0.003	Yes
		1:2:1		≤-40			
H	Low dew point clean air (for clean room)	1:1:1		≤-70			

Product name	Sub line						Local line										Specialised filtration							
	Main line filter		Refrigerated air dryer		Water separator		Mist separator		Micro mist separator		Membrane air dryer		Activated carbon filter		Clean air filter	Clean gas filters	Bacteria removal filter							
Model	AF-D	AFF20-60D	AFF70-90D	IDFA3-15E	IDFA60/70/80/90	IDFA100/125/150F	AFG-D	AFM-D	AM20-60D	AM70-90D	AFD-D	AMD20-60D	AMD70-90D	IDG-D	IDG	AMK	AMF450C-550C / 650-850	SFD	SFA, SFB, SFC	HF2-BFA	HF2-BFB	HF2-BFC	HF2-BFD	HF2B-SFDA
Maximum air flow (l/min) (ANR) 0.7 MPa	14550	3700	14500	13700	16000	22700	4000	1100	3700	14500	600	3700	14500	500	1000	3700	12000	500	300	800				500
Maximum inlet air temperature	60 °C		50 °C		65 °C		60 °C						50 °C	55 °C	60 °C		45 °C	80 °C, 120 °C	60 °C				45 °C	
Nominal filtration degree (filtering efficiency)	5 µm	1 µm (99 %) Water droplet removal rate: 99 %		—		—		0.3 µm (99.9 %)	0.1 µm (99 %)	—		0.01 µm (99.9 %)		—		0.01 µm (99.9 %)		0.01 µm (99.9 %)	0.01 µm (99.9 %)	5 µm (90 %)	0.1 µm (99 %)	—		0.01 µm (99.99 %)
Outlet oil mist concentration: max. ¹⁾	—		—		—		1.0 mg/m ³ (ANR) [0.8 ppm]		—		0.1 mg/m ³ (ANR) [0.08 ppm]		—		0.003 mg/m ³ [0.0025 ppm]		0.004 mg/m ³ (ANR) [0.0032 ppm]		—				0.003 mg/m ³ [0.0025 ppm]	—
Outlet ISO purity grade ²⁾	6:4:4	5:4:4		—		—		3:4:3	2:4:3	—		1:4:2		—		1:4:1		Not rated		—				—
Pressure dew point (Inlet pressure 0.7 MPa)	—		3 °C		—						-57 °C	-60 °C	—											

